

Low Pressure Bag Filter Housing

cellar.tek

Design P. 10kg/cm² Operating P. 7kg/cm²

Design T. 100°C Operating T. 75°C

Accessory Filter bag, Bag pressing, Bag bracket.



BFL 1 4 50 10K SB E 12

Product code	Length of Bag	Material	In & Outlet Size	In & Outlet Type	In & Outlet	O-ring Material	Interior surface finished
	1 - No.1Bag 2 - No.2Bag 3 - No.3Bag 4 - No.4Bag	4 - 304 6 - 316 6L - 316L	15 - 1/2" 20 - 3/4" 25 - 1" 40 - 1-1/2" 50 - 2" 65 - 2-1/2" 80 - 3"	10K - JIS 150P - ANSI PN10 - DIN J - Clamp PF - PTF BF - BSPF NF - NPTF PM - PTM BM - BSPM NM - NPTM	SB - (Side In& Bottom Out)	E - EPDM V - Viton N - NBR S - Silicone TS - Teflon + Silicone	1 - Acid Washing 2 - Electrolyze 3 - Polishing Exterior surface finished 1 - acid washing 2 - Electrolyze 3 - Polishing

Low Pressure Bag Filter Housing

No.	Description	No.	Description	No.	Description
1	Clamp	6	Shell Flange	11	Shell
2	Vent	7	Port inlet	12	Bottom cover
3	Top cover	8	Port outlet	13	Support Leg
4	Basket	9	Filter bag plate		
5	O-ring	10	Bolt		

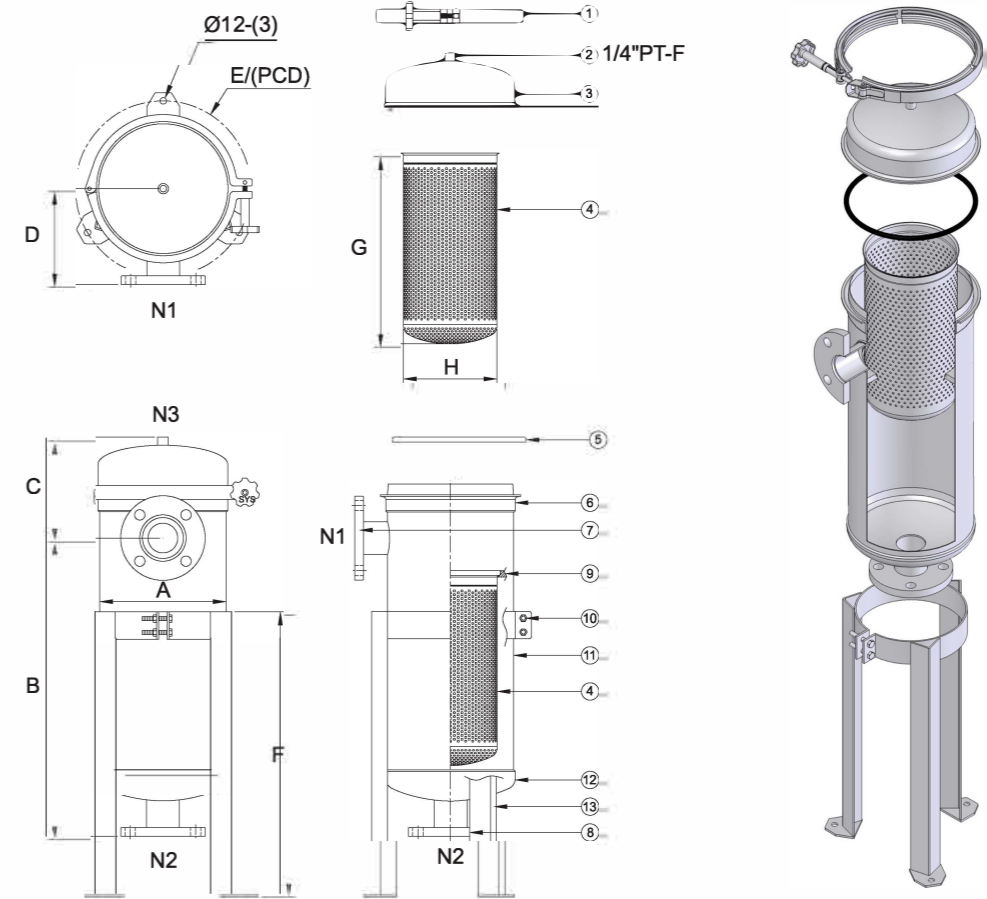

Model	A m/m	B m/m	C m/m	D m/m	E(PCD) m/m	F m/m	G m/m	H m/m	M ³ /Hr	GPM	Weight	Volume
BFL-2	Ø232	1005	185	176	Ø323	600	730	Ø171.5	45	200	26kg	46L

cellar.tek