

Design P. 15kg/cm<sup>2</sup> Operating P. 10kg/cm<sup>2</sup>

Design T. 100°C Operating T. 75°C

Accessory Filter bag. Bag pressing. Bag bracket.

Some parts are unavailable For polishing



**BFH 1 4 50 10K SB E 12**

Product code

Length of Bag  
エレメント  
1 - No.1Bag  
2 - No.2Bag

Material  
4 - 304  
6 - 316

In & Outlet Size  
15 - 1/2"  
20 - 3/4"  
25 - 1"  
40 - 1-1/2"  
50 - 2"  
65 - 2-1/2"  
80 - 3"

In & Outlet Type  
10K - JIS  
150P - ANSI  
PN10 - DIN  
J - Clamp  
PF - BSPT-F  
BF - BSPF-F  
NF - NPT-F

In & Outlet  
SS - (Side In&Out)  
SB - (Side In&Bottom Out)

O-ring Material  
E - EPDM  
V - Viton  
N - NBR  
S - Silicone  
TV - Teflon + Viton

Interior surface finished

1. Acid wash  
2. Electrolyze  
3. Polishing

Exterior surface finished

1. Acid wash  
2. Electrolyze  
3. Polishing

No.	Description	No.	Description	No.	Description
1	Handle	7	Eye bolt	13	Port outlet
2	Top cover	8	Washer	14	Bolt
3	Vent	9	Eye nut	15	Support leg
4	O-ring	10	Filter bag plate	16	Basket
5	Shell flange	11	Shell		
6	Spindle	12	Port inlet		

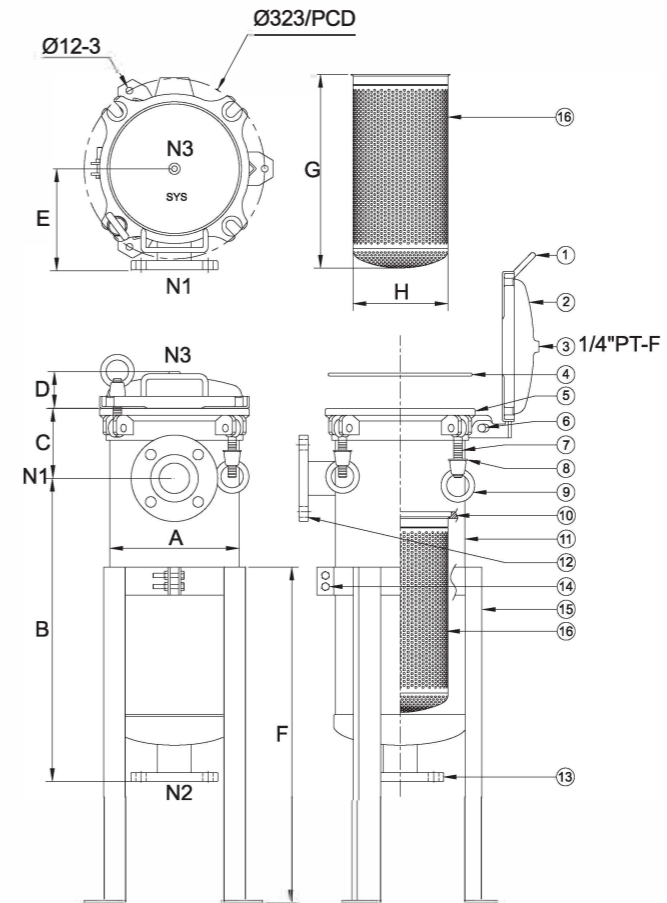

Model	A m/m	B m/m	C m/m	D m/m	E m/m	F m/m	G m/m	H m/m	M <sup>3</sup> /Hr	GPM	Weight	Volume
BFH-1	Ø232	545	125	65	176	600	350	Ø171.5	20	90	34kg	23L
BFH-2	Ø232	925	125	65	176	600	730	Ø171.5	45	200	43kg	37L