

EQUIPAGGIAMENTI
TECNICI
LAVAGGIO

TESTINE ROTANTI

MOD. M25E ASPIRANTE



4 13

12.9413.00

20/12/05

M25E

- 25.4350.00 (I)-220Vca
- 25.4350.25 (I)-24Vca
- 25.4350.60 (USA)-110Vca
- 25.4350.24 (AUS)-240Vca

MANUALE D'ISTRUZIONE
GENERAL INTRUCTION BOOK

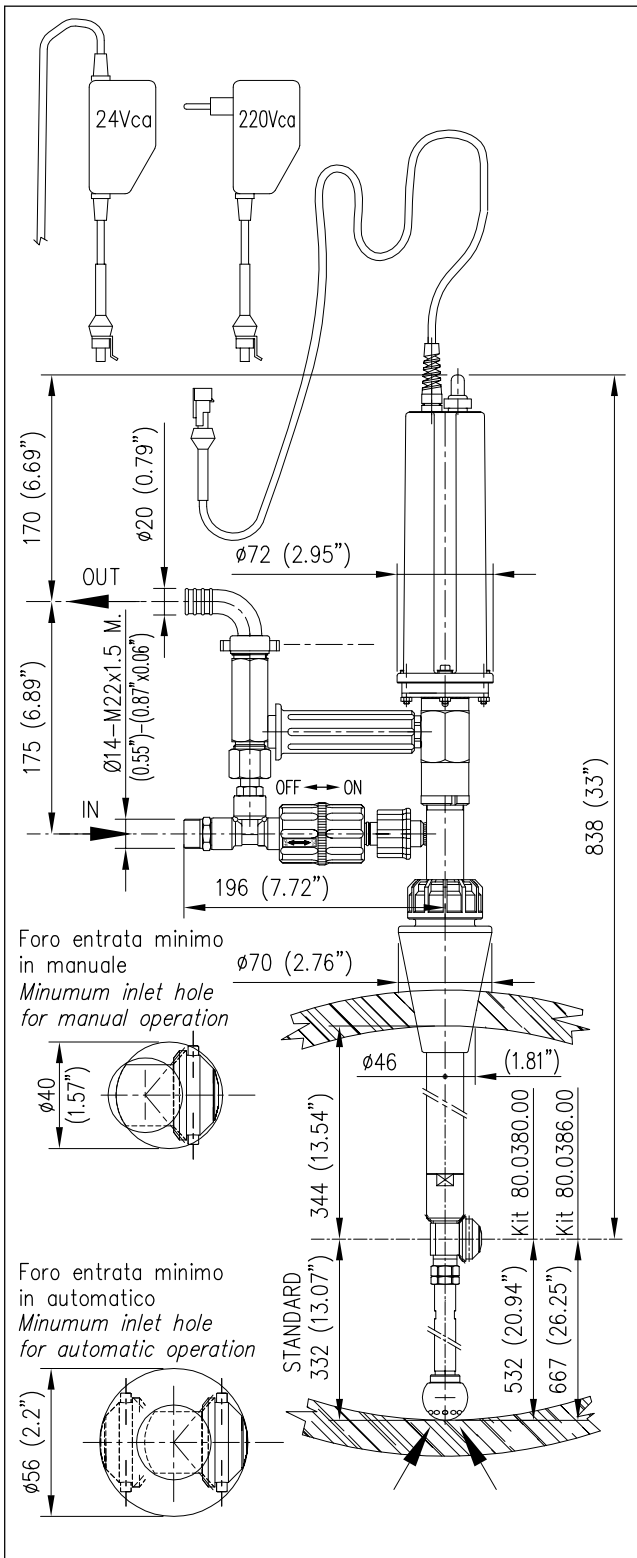

TESTINA ELETTRICA PULIZIA
CONTENITORI E BOTTI.
ASPIRAZIONE INTERNA INTEGRATA.

- Testina per il lavaggio di contenitori e botti con sistema di aspirazione e scarico esterno del liquido utilizzato per il lavaggio.
- Portata ridotta, alta pressione, elevata forza di impatto.
- Copertura orbitale completa degli interni.
- Minimo ingombro radiale che ne permette l'introduzione attraverso passaggi ridotti.
- Alimentazione elettrica a bassa tensione.
- Costruzione in acciaio inox.
- Idonea per impiego settore alimentare.

ATTENZIONE !

- La Testina STANDARD è fornita di guarnizioni (DINAMICHE) in PTFE + O-Ring EPDM.
- Lubrificare esclusivamente con GRASSO SILICONICO codice: 14.6552.00
- Per l'utilizzo di liquidi detersivi, additivi chimici ecc. non compatibili con le guarnizioni standard è indispensabile contattare il nostro UFFICIO TECNICO.
- A richiesta le guarnizioni (DINAMICHE) O-RING sono disponibili anche in diverso materiale, NBR-FFKM(kalrez)-FKM(viton).
- Le guarnizioni (STATICHE) sono in FKM (viton).

ELECTRICAL HEAD DESIGNED TO
CLEAN SMALL TANKS AND BARRELS,
EQUIPPED WITH SUCTION SYSTEM.

- Tank cleaning head ideal for cleaning all types of tanks and barrels. It washes and, at the same time, siphons off the water used during the cleaning process.
- Reduced flow, high pressure, high cleaning impact.
- Complete orbital coverage of all interior surfaces.
- Reduced spray turret that fits through small barrel and tank openings.
- Low tension electric power.
- Stainless steel construction.
- Suitable for utilization in food industry.

ATTENTION !

- The STANDARD Tank cleaning head is supplied with seals (DYNAMIC) in PTFE + O-Ring EPDM.
- Lubricate ONLY with SILICONE GREASE P/N: 14.6552.00
- For use with Detergent liquid, Chemical additives etc that are not compatible with the standard seals, it is essential to contact our TECHNICAL OFFICE for further information.
- On request, the O-RING seals (DYNAMIC) are available in different materials such as NBR-FFKM(kalrez)-FKM(viton).
- The STATIC seals are in FKM (viton).

	A	B max.
-Testina standard	Ø46	Ø730
-Testina + Kit 80.0380.00	Ø50	Ø940
-Testina + Kit 80.0386.00	Ø50	Ø1070

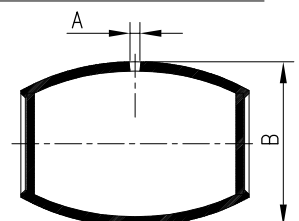

ATTENZIONE: NON UTILIZZARE L'APPARECCHIO PRIMA DI AVER LETTO QUESTO MANUALE DI ISTRUZIONE

CAUTION: DO NOT USE THE CLEANING HEAD BEFORE HAVING READ THE INSTRUCTION BOOK

CARATTERISTICHE TECNICHE TECHNICAL SPECIFICATIONS

M25E



21/01/09

- PRESSIONE NOMINALE RATED PRESSURE	MIN 60 bar - 6 MPa (870 psi)	140 bar - 14 MPa (2000 psi)
- PRESSIONE CONSENTITA PERMISSIBLE PRESSURE		160 bar - 16 MPa (2300 psi)
- PORTATA MASSIMA MAX FLOW RATE	MIN 10 l/min (2,6 USGp.m.)	25 l/min (6,5 USGp.m.)
- FATTORE DI PORTATA UGELLO VENTURI (ASPIRAZIONE) FLOW FACTOR OF THE VENTURI NOZZLE (SUCTION)		F.P. 02
- TEMPERATURA MASSIMA ACQUA MAX WORKING TEMPERATURE		90 °C (195°F)
- PESO WEIGHT		5.2 Kg
- FREQUENZA ROTAZIONE ASSE PRINCIPALE MAIN AXIS ROTATING SPEED		14 RPM
- ATTACCO ALIMENTAZIONE ACQUA INLET CONNECTION SIZE		ø14-M22x1.5 M (A)
- ATTACCO SCARICO ACQUA (PORTAGOMMA) WATER OUTLET FITTING (HOSE BARB)		ø20
- ATTACCO UGELLI N°2 NOZZLES CONNECTION N°2		M4
- TEMPO PER UN CICLO COMPLETO DI LAVAGGIO TIME FOR A COMPLETE CLEANING CYCLE		3 min
- MOTORE ELETTRICO: ELECTRIC MOTOR:		8W - 12V.cc
- ALIMENTATORE: POWER SUPPLY:	25.4350.00/25.4355.00 - 230V-50Hz/12V.cc-1A 25.4350.25 - 24V-ca/12V.cc-1A 25.4350.60 - 110V-60Hz/12V.cc-0.8A 25.4350.24 - 240V-50Hz/12V.cc-1A	
- LUNGHEZZA CAVO ALIMENTAZIONE: POWER CABLE LENGTH		10 m
- TENUTE (N.B. USARE SOLO GRASSO AL SILICONE codice:14.6552.00) SEALS (N.B. USE P/N: 14.6552.00 SILICONE GREASE ONLY)		(EPDM+PTFE) (VITON)

CADUTA DI PRESSIONE IN FUNZIONE DELLA PORTATA

LOSS OF PRESSURE IN RELATION TO FLOW

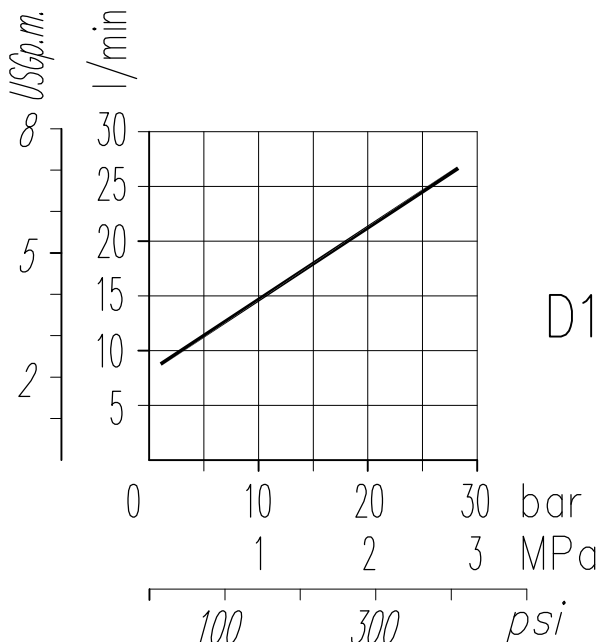

D2

UGELLI - NOZZLES

	codice	D(mm)	l/min(100bar)	F.P.
*	80.0350.51	1.00	4.6	02
	25.1191.51	1.05	5	023
*	80.0351.51	1.10	5.6	025
	25.1192.51	1.15	6.1	027
*	80.0352.51	1.20	6.7	03
	25.1193.51	1.25	7.1	032
*	80.0353.51	1.30	7.8	035
	25.1098.51	1.35	8.4	037
*	80.0354.51	1.40	9.1	04
	25.1194.51	1.45	9.7	043
	25.1095.51	1.50	10.3	045
	25.1195.51	1.55	11.2	05
	25.1196.51	1.60	12	053
	25.1197.51	1.62	12.6	055
	25.1186.51	1.66	13.7	06
	25.1198.51	1.72	14.8	065
	25.1199.51	1.8	16	07
	25.1085.51	2.00	18.2	08

* Ugelli forniti di serie (tipo corto)

* Standard nozzles supplied (short type) 12-2

SCELTA INDICATIVA FATTORE DI PORTATA N°2 UGELLI
 INDICATIVE CHOICE OF FLOW FACTOR N°2 NOZZLES

PRESSIONE bar – MPa – PRESSURE PSI

PORTATA POMPA l/min – PUMP FLOW GMP

25 6,5									160 16 2300	145 14,5 2100	135 13,5 1960	125 12,5 1810	110 11 1600	100 10 1450	95 9,5 1380	85 8,5 1230	70 7 1010	60 6 870	
24 6,3							165 16,5 2400	150 15 2200	135 13,5 1960	125 12,5 1810	115 11,5 1670	100 10 1450	95 9,5 1380	90 9 1300	80 8 1150	65 6,5 940			
23 6,1							155 15,5 2250	140 14 2000	125 12,5 1810	115 11,5 1670	105 10,5 1560	95 9,5 1380	85 8,5 1230	80 8 1150	75 7,5 1080	60 6 870			
22 5,8						160 16 2300	140 14 2000	125 12,5 1810	115 11,5 1670	105 10,5 1520	100 10 1450	85 8,5 1230	80 8 1150	75 7,5 1080	70 7 1010				
21 5,5					155 15,5 2250	145 14,5 2100	125 12,5 1810	115 11,5 1670	105 10,5 1560	95 9,5 1380	90 9 1300	80 8 1150	75 7,5 1080	70 7 1010	65 6,5 940				
20 5,3			160 16 2300	140 14 2000	130 13 1900	115 11,5 1670	105 10,5 1560	95 9,5 1380	85 8,5 1230	80 8 1150	75 7,5 1080	65 6,5 940	60 6 870						
19 5			160 16 2300	145 14,5 2100	130 13 1900	120 12 1750	105 10,5 1520	95 9,5 1380	85 8,5 1230	80 8 1150	75 7,5 1080	65 6,5 940	60 6 870						
18 4,8		165 16,5 2400	145 14,5 2100	130 13 1900	115 11,5 1670	105 10,5 1520	95 9,5 1380	85 8,5 1230	80 8 1150	70 7 1010	65 6,5 940	60 6 870							
17 4,5	165 16,5 2400	150 15 2200	130 13 1900	115 11,5 1670	100 10 1450	95 9,5 1380	85 8,5 1230	75 7,5 1080	70 7 1010	65 6,5 940									
16 4,2	145 14,5 2100	130 13 1900	115 11,5 1670	100 10 1450	90 9 1300	85 8,5 1230	75 7,5 1080	70 7 1010	60 6 870										
15 4	130 13 1900	115 11,5 1670	100 10 1450	90 9 1300	80 8 1150	75 7,5 1080	65 6,5 940	60 6 870											
14 3,7	110 11 1600	100 10 1450	90 9 1300	80 8 1150	70 7 1010	65 6,5 940													
13 3,4	95 9,5 1380	85 8,5 1230	75 7,5 1080	65 6,5 940	60 6 870														
12 3,2	80 8 1150	75 7,5 1080	60 6 870																
11 2,9	70 7 1010	60 6 870																	
FATTORE PORTATA N°1 UGELLO FLOW FACTOR N°1 NOZZLE	*	02	023	* 025	027	* 03	032	035	037	*	04	043	045	05	053	055	06	07	08
N° UGELLI DA MONTARE N° OF NOZZLES TO BE FITTED	2	2	2	2	2	2	2	2	2	2	2	2	2	2	2	2	2	2	2

* UGELLI DISPONIBILI TIPO CORTO
 * NOZZLES AVAILABLE SHORT TYPE

N.B. E' OBBLIGATORIO MONTARE N°2 UGELLI AVENTI LO STESSO FATTORE DI PORTATA
 N.B. IT IS MANDATORY TO FIT 2 NOZZLES HAVING THE SAME FLOW FACTOR

	EQUIPAGGIAMENTI TECNICI LAVAGGIO	MONTAGGIO RAMO ALIMENTAZIONE M25E FEEDER GROUP ASSEMBLY M25E MONTAGE DU GROUPE D'ALIMENTATION M25E MONTAGE DES ANSAUGAGGREGATES DER M25E	I F	GB D	4	13
			12.9413.05	15/12/03		

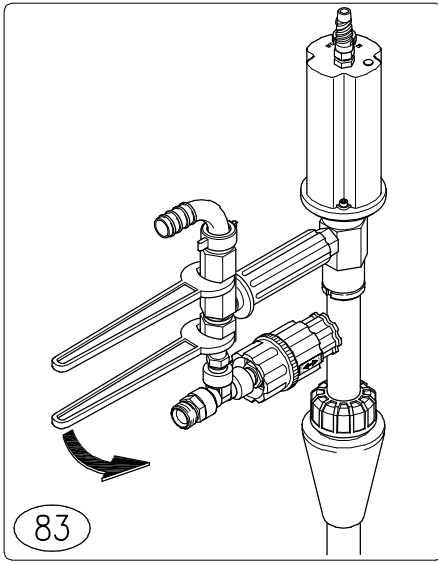
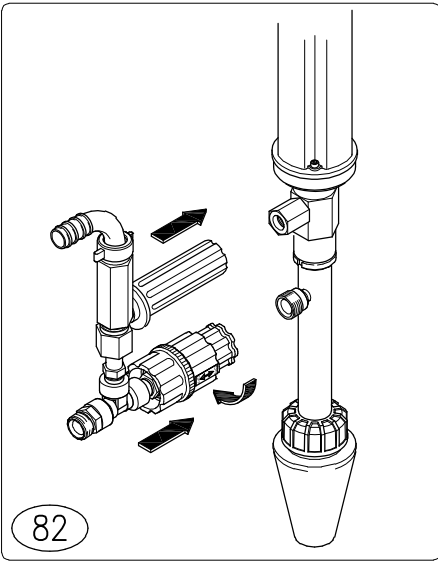
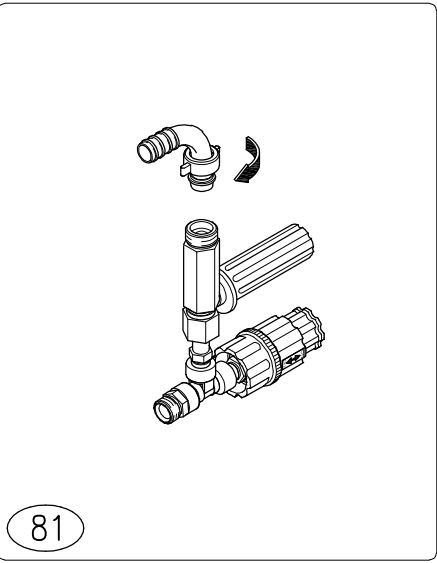
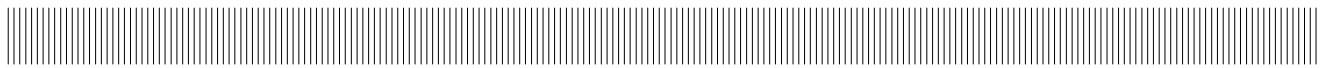

ITALIANO

- Avvitare il raccordo a curva come indicato in fig.81.
- Unire il gruppo aspirazione appena montato alla testina. Introdurre la maniglia nel raccordo sul manicotto ed avvitare contemporaneamente la ghiera al filetto sul tubo (fig.82).
- Con due chiavi a forcina di 27 mm stringere il raccordo e la ghiera come in fig.83.

ENGLISH

- Screw on the curve joint as shown in fig.81.
- Assemble the suction group that has just been mounted to the head. Insert the handle into the joint on the sleeve and at the same time screw the ring nut to the thread on the tube (fig.82).
- With two 27 mm fork wrenches tighten the joint and the ring nut as in fig.83.

FRANÇAIS

- Visser le raccord courbé comme le montre la fig.81.
- Unir à la tête le groupe aspiration qui vient d'être monté. Introduire la poignée dans le raccord sur le manchon et visser dans le même temps la bague au filet sur le tube (fig. 82).
- Avec deux clefs à fourche de 27 mm, serrer le raccord et la bague comme le montre la fig.83.

DEUTSCH

- Das gebogene Rohr wie auf Abbildung 81 gezeigt anschrauben.
- Das soeben montierte Ansaugaggregat mit dem Kopf verbinden. Den Griff in den Anschluss an der Muffe einführen und gleichzeitig die Überwurfmutter am Gewinde des Rohres anschrauben (Abb.82).
- Den Anschluss und die Überwurfmutter wie auf Abbildung 83 gezeigt mit zwei Maulschlüsseln zu 27 mm festziehen.



P.A. – S.p.A. – EQUIPAGGIAMENTI TECNICI DEL LAVAGGIO

VIA MILANO, 13 – CASELLA POSTALE 115 – 42048 RUBIERA (REGGIO EMILIA) – ITALY
Tel. +39 0522 623611 – Fax. +39 0522 629600 – R.E.A. RE 156319 – R.I. RE11535 – Mecc. RE 013446
C.F. e P. IVA 01035950359 – Cap. Soc. i.v. € 750.000,00 – Codice Identificativo C.E.E. IT 01035950359
ART. 2497 – BIS C.C. DIREZIONE E COORDINAMENTO BENETTI srl R.I. TRIB. DI RE 01480690351
Web: <http://www.pa-etl.it> – E-mail: info@pa-etl.it



EU DECLARATION OF CONFORMITY 2014/30/EU

We under signed declare under our responsibility that the product:

Noi firmatari della presente dichiariamo sotto la nostra responsabilità che il prodotto:

CLEANING HEAD – M21E – M25E – M28E
ACCESSORIO PER IL LAVAGGIO A TESTINA ROTANTE – M21E – M25E – M28E

to which this declaration relates is in conformity with the following standards or other normative document(s):

al quale questa dichiarazione si riferisce, è conforme alle seguenti norme:

- **CEI EN 55014-1:2008 + A1:2010 + A2:2012 – Requirements for household appliances, electric tools and similar apparatus - Part 1: Emission**
- *Prescrizione per gli elettrodomestici, gli utensili elettrici e gli apparecchi similari – Parte 1: Emissione*
- **CEI EN 55014-2:2015 – Requirements for household appliances, electric tools and similar apparatus - Part 2: Immunity - Product family standard**
- *Prescrizione per gli elettrodomestici, gli utensili elettrici e gli apparecchi similari – Parte 2: Immunità – Norma di famiglia per prodotti*
- **CEI EN 60335-1:2013 + A11:2015 – Household and similar electrical appliances - Safety - Part 1: General requirements**
- *Sicurezza degli apparecchi d'uso domestico e similare – Sicurezza – Parte 1: Norme generali*

following the provisions of the Directive: 2014/30/EU.

in base a quanto previsto dalla Direttiva: 2014/30/UE.

Restrictions

When installed with other products or as part of an assembly, the EMC characteristics might change. In this case the manufacturer of the final product has to check the EMC characteristics to ensure that they are still in compliance with EMC Directive.

Limitazioni

Quando installato in altri prodotti o come parte di un insieme, le caratteristiche EMC possono essere alterate. Pertanto in tal caso il costruttore del prodotto finito deve verificare nuovamente le caratteristiche EMC per assicurare che siano ancora in conformità con la Direttiva EMC.

We also declare:

Si dichiara inoltre:

that the pressure apparatus has been submitted with successful outcome to hydraulic pressure test;

che l'attrezzatura a pressione è stata sottoposta con esito favorevole a prova di pressione idraulica.

Rubiera, li 24/05/2017.

P.A. SpA
Il PRESIDENTE
Ing. Arnaldo Benetti

25.4350.00 M25E test.mot.el+aspir.220Vca/50Hz
25.4350.25 M25E test.mot.el+aspir.24Vca

25.4350.60 M25E test.mot.el+aspir.115Vca/60Hz USA

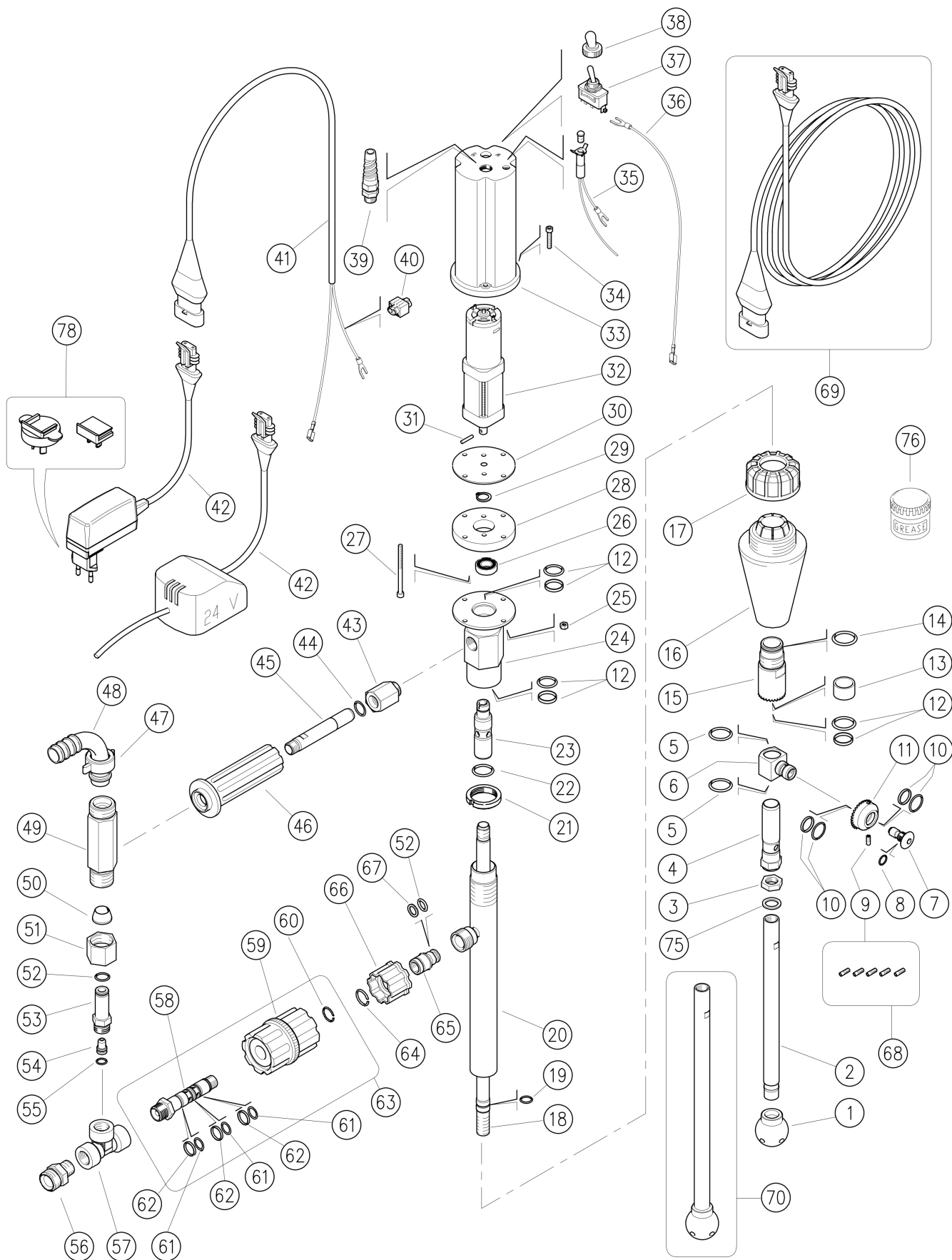

Pos.	Codice	Descrizione	Q.tà	K1	K2	K3	K4		Pos.	Codice	Descrizione	Q.tà	K1	K2	K3	K4	
1	80.0330.81	Respingente forato POM bianco	1					5	36	12.5019.25	Cavo 1x0,75 L.250 mm	1					5
2	80.0329.56	Tubo aspirante G1/4F 280mm inox	1					5	37	12.5016.20	Interr.unipol. on/off +protezione	1					3
3	80.0328.51	Ghiera G1/4F inox	1					5	39	13.5997.00	Pressacavo 1/4 +protezione	1					5
4	80.0327.51	Perno porta guarnizioni inox	1					5	40	12.5019.47	Rubacorrente	1					5
5	10.3010.10	An.OR 1x18 mm Vi 70	2		.	.	.	10	41	12.5019.10	Cavo 2x1,5 mm 10m+connessione F	1					5
6	80.0331.51	Statore inox	1					1	42	12.5071.00	Trasf. 230Vca/12Vcc EU (1)	1					1
7	80.0325.51	Perno M10x1 inox	1					1	42	12.5071.24	Trasf. 240Vca/12Vcc AUS	1					1
8	10.3055.10	An.OR 1,78x7,66 mm Vi 70	1		.	.	.	10	42	12.5071.25	Trasf. 24Vca/12Vcc EU (2)	1					1
9	15.3704.00	Tappo M4 plast.	2					4	42	12.5071.60	Trasf. 115Vca-60Hz/12Vcc USA (3)	1					1
9	80.0350.51	Ugello 02 - 1,0mm - M4 inox verde ch.	2	.				10	43	80.0338.31	Racc. M16x1 M ott.+Ni	1					10
9	80.0351.51	Ugello 025 - 1,1mm - M4 inox rosa	2	.				10	44	10.3179.10	An.OR 2,62x13,94 mm Vi 70	1		.	.	.	10
9	80.0352.51	Ugello 03 - 1,2mm - M4 inox bianco	2	.				10	45	80.0337.56	Tubo aspirazione G1/4M 113mm inox	1					3
9	80.0353.51	Ugello 035 - 1,3mm - M4 inox marrone	2	.				10	46	80.0344.85	Manopola 32x110mm PP nera	1					5
9	80.0354.51	Ugello 04 - 1,4mm - M4 inox giallo	2	.				10	47	80.0347.35	Girello G3/4 ott.+Ni	1					5
10	10.2030.00	Guarn. stelo 15x20x2,2 mm +OR	2	4	48	80.0346.35	Gomito ptgm 20mm ott.+Ni	1					3
11	80.0326.51	Pignone portaug. z.41 M4 FF inox	1					3	49	80.0336.31	Racc. venturi ott.+Ni	1					3
12	10.2030.18	Guarn. stelo 18x23x2 mm +OR Epdm	3	5	50	80.0335.81	An.conico a. 14x20x11mm POM bianco	1					10
13	80.0024.85	Boccola a. 18x22x14,8mm PTFE	1					5	51	80.0334.31	Ghiera M24x1,5 ott.+Ni	1					5
14	10.3026.10	An.OR 1,5x20 mm Vi 70	1	10	52	10.3109.95	An.OR 2,4x9,3 mm Vi 70	2	25
15	80.0372.23	Pignone z.34 inox+Bocc.ap. PTFE	1					3	53	80.0333.31	Racc. porta ugello G3/8M ott.+Ni	1					3
16	80.0021.84	Tappo conico TPEs nero	1					3	54	25.0019.51	Ugello 02 d.10,5x15 mm inox	1					5
17	80.0316.84	Ghiera PP nera	1					10	55	10.3052.00	An.OR 1,78x6,75 mm	1	25
18	80.0322.56	Tubo G1/4 MM 600mm inox	1					3	56	80.0348.31	Racc. G3/8M-M22x1 M ott.+Ni	1					3
18	80.0389.56	Tubo G1/4 MM 500mm inox	1					3	57	80.0349.35	Racc. a T G3/8 FFF ott.+Ni	1					3
19	10.3007.10	An.OR 1x12 mm Vi 70	1	10	58	80.0402.31	Racc. distrib. G3/8M-G1/4M ott.	1					3
20	80.0343.21	Tubo + raccordo M22 inox	1					3	59	80.0403.21	Manopola PA nera + Inserto ott.	1					3
21	80.0012.51	Ghiera M28x1 inox	1					1	60	29.0402.51	An. elast. 1,6x14,3 mm inox	1					5
22	10.3205.10	An.OR 2,62x26,64 mm Vi 70	1	10	61	10.3058.10	An.OR 1,78x10,82 mm Vi 70	3			.	.	10
23	80.0321.51	Albero di trasmissione inox	1					1	62	10.4058.00	An.tenuta 14x16x2 mm	3			.	.	10
24	80.0341.21	Collettore inox	1					2	63	80.0400.00	Regolat. di portata RF1 G3/8M-G1/4M	1					3
25	11.4513.10	Dado es. M4 inox	4					10	64	26.0252.51	An. elast. 1,5x15,5 mm inox	1					10
26	11.4412.28	Cuscinetto 12x28x8 mm - 2RS1 inox	1					3	65	26.0261.31	Spinotto 14mm-G1/4F ott.	1					10
27	16.1860.00	Vite DIN912 M4x60 mm inox	2					10	66	26.0260.22	Girello M22x1,5 17,5mm nero	1					10
28	80.0318.41	Flangia motore	1					3	67	10.4010.01	An. anties. a. 10,2x13,9x1,2 mm	1	50
29	10.0999.05	An. elast. E 12 inox	1					10	68	25.4320.24	Kit Ugelli M4 - M21E 2x5pz.	1					1
30	80.0317.88	Guarniz. per motore, NBR	1					2	69	25.4353.20	Prol. -M21E 20m 12Vcc MF **	1					1
31	15.1030.00	Spina elast. 3x16 mm inox	1					10	70	80.0380.00	Tubo aspirante per botte Ø940mm **	1					1
32	13.0827.00	Motoriduttore 12V 10Rpm	1					1	70	80.0386.00	Tubo aspirante per botte Ø1070mm **	1					1
33	80.0301.84	Carter motore PA nero	1					1	71	10.3066.10	An.OR 1,78x15,6 mm Vi 70	2		.	.	.	10
34	16.1856.00	Vite DIN912 M4x25 mm inox	4					10	75	14.3911.00	Rosetta 13,5x19x1,5 mm Cu	1					10
35	12.5019.31	Lampada spia	1					5	76	14.6552.00	Grass.silicone-teflon-30g.>tutti imp. **	1					2

** Su richiesta

Kit	Codice	Descrizione	
K1	25.4320.24	Kit Ugelli M4 - M21E 2x5pz.	1
K2	25.4356.24	Kit ric.guarn. M25E (mat.1-100) 13x1pz.	1
K3	25.4357.24	Kit ric.guarn.M25E (mat.101-518) 12x1pz	1
K4	25.4360.24	Kit ric.guarn. M25E (mat.519>) 13x1pz.	1

(1) 25.4350.00 (2) 25.4350.25 (3) 25.4350.60

25.4350.00 M25E Barrel cl.,elect.driv+suction
25.4350.25 M25E Barrel cl.,el.driv+suct.24V AC

25.4350.60 M25E Barrel cl.,+suct. 115V AC/60Hz USA

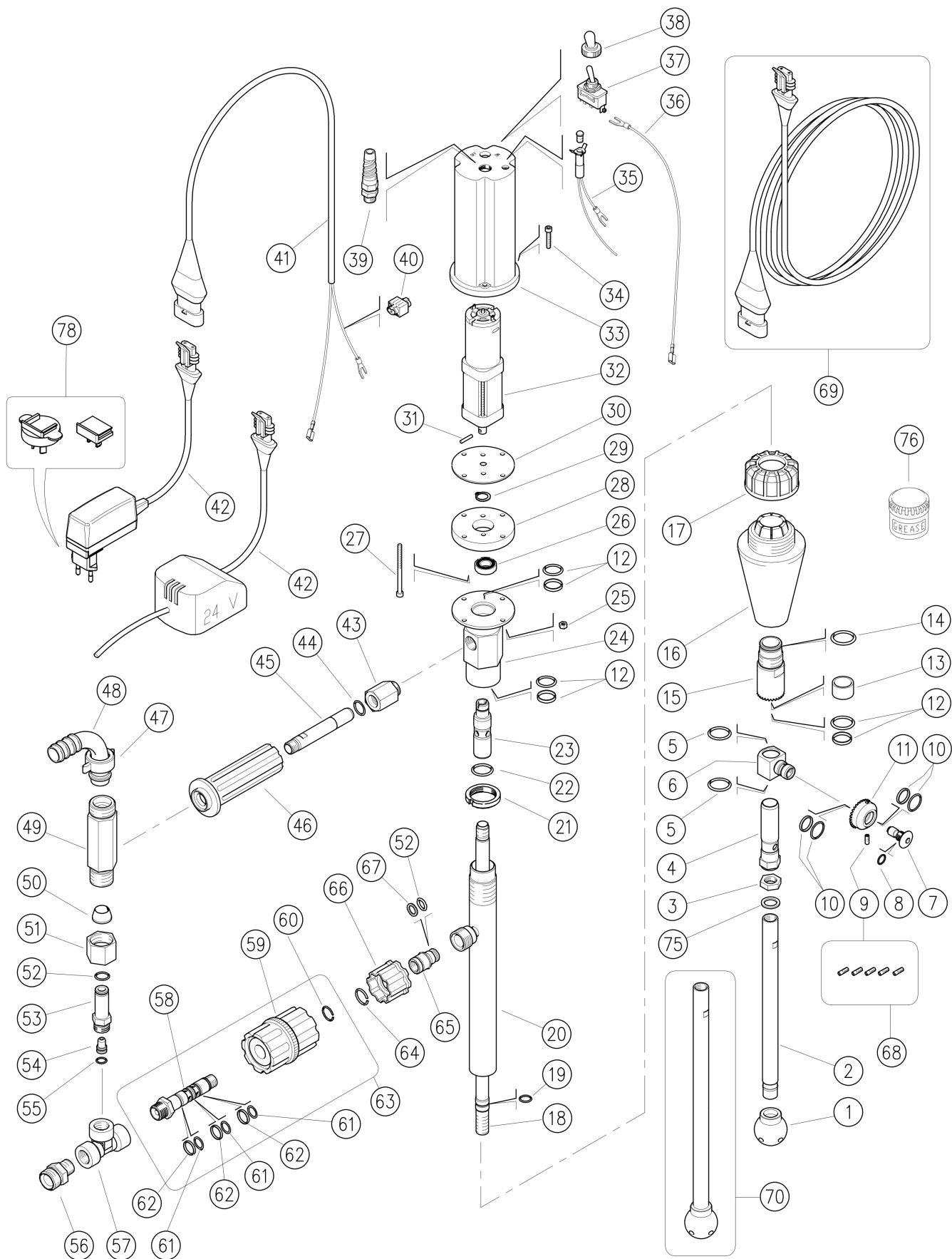

Pos.	P/N	Description	Q.ty	K1	K2	K3	K4	
1	80.0330.81	Pierced buffer, POM white	1					5
2	80.0329.56	Suction tube, 1/4F Bsp 280mm Sst.	1					5
3	80.0328.51	Ring nut, 1/4F Bsp Sst.	1					5
4	80.0327.51	Seal holding pin, Sst.	1					5
5	10.3010.10	O-ring, 1x18 mm Vi 70	2	•	•	•		10
6	80.0331.51	Stator, Sst.	1					1
7	80.0325.51	Pin, M10x1 Sst.	1					1
8	10.3055.10	O-ring, 1,78x7,66 mm Vi 70	1	•	•	•		10
9	15.3704.00	Plug, M4 plast.	2					4
9	80.0350.51	Nozzle, 02 - 1,0mm - M4 Sst. light green	2	•				10
9	80.0351.51	Nozzle, 025 - 1,1mm - M4 Sst. pink	2	•				10
9	80.0352.51	Nozzle, 03 - 1,2mm - M4 Sst. white	2	•				10
9	80.0353.51	Nozzle, 035 - 1,3mm - M4 Sst. brown	2	•				10
9	80.0354.51	Nozzle, 04 - 1,4mm - M4 Sst. yellow	2	•				10
10	10.2030.00	Stem seal, 15x20x2,2 mm +O-ring	2	•	•	•		4
11	80.0326.51	Nzl hold. pinion, z.41 M4 FF Sst.	1					3
12	10.2030.18	Stem seal, 18x23x2 mm +O-ring Epdm	3	•	•	•		5
13	80.0024.85	Bushing, opn. 18x22x14,8mm PTFE	1					5
14	10.3026.10	O-ring, 1,5x20 mm Vi 70	1	•	•	•		10
15	80.0372.23	Pinion, z.34 Sst.+bushing,opn.PTFE	1					3
16	80.0021.84	Tapered plug, TPEs black	1					3
17	80.0316.84	Ring nut, PP black	1					10
18	80.0322.56	Tube, 1/4Bsp MM 600mm Sst.	1					3
18	80.0389.56	Tube, 1/4Bsp MM 500mm Sst.	1					3
19	10.3007.10	O-ring, 1x12 mm Vi 70	1	•	•	•		10
20	80.0343.21	Tube + coupling, M22 Sst.	1					3
21	80.0012.51	Ring nut, M28x1 Sst.	1					1
22	10.3205.10	O-ring, 2,62x26,64 mm Vi 70	1	•	•	•		10
23	80.0321.51	Propeller shaft, Sst.	1					1
24	80.0341.21	Manifold, Sst.	1					2
25	11.4513.10	Hex. nut, M4, Sst.	4					10
26	11.4412.28	Ball-bearing, 12x28x8 mm - 2RS1 Sst.	1					3
27	16.1860.00	Screw, DIN912 M4x60 mm Sst.	2					10
28	80.0318.41	Motor flange	1					3
29	10.0999.05	Snap ring, E 12 Sst.	1					10
30	80.0317.88	Motor seal, NBR	1					2
31	15.1030.00	Roll pin, 3x16 mm Sst.	1					10
32	13.0827.00	Gearmotor, 12V 10Rpm	1					1
33	80.0301.84	Motor casing, PA black	1					1
34	16.1856.00	Screw, DIN912 M4x25 mm Sst.	4					10
35	12.5019.31	Pilot lamp	1					5
36	12.5019.25	Cable, 1x0,75 L.250 mm	1					5
37	12.5016.20	On/off unipol. switch+protec.	1					3
39	13.5997.00	Cable gland 1/4 +protection	1					5
40	12.5019.47	Wire tap-in	1					5
41	12.5019.10	Cable, 2x1,5 mm 10m+F connection	1					5
42	12.5071.00	Transf. 230VAC/12VDC EU (1)	1					1
42	12.5071.24	Transf. 240VAC/12VDC AUS	1					1
42	12.5071.25	Transf. 24VAC/12VDC EU (2)	1					1
42	12.5071.60	Transf. 115VAC-60Hz/12VDC USA (3)	1					1
43	80.0338.31	Coupl., M16x1 M brass+Ni	1					10
44	10.3179.10	O-ring, 2,62x13,94 mm Vi 70	1	•	•	•		10
45	80.0337.56	Intake tube, 1/4M Bsp 113mm Sst.	1					3
46	80.0344.85	Knob, 32x110mm PP black	1					5
47	80.0347.35	Hand nut, G3/4 brass+Ni	1					5
48	80.0346.35	Elbow+hose barb, 20mm brass+Ni	1					3
49	80.0336.31	Venturi fitting, brass+Ni	1					3
50	80.0335.81	Taper.ring.opn. 14x20x11mm POM white	1					10
51	80.0334.31	Ring nut, M24x1,5 brass+Ni	1					5
52	10.3109.95	O-ring, 2,4x9,3 mm Vi 70	2	•	•	•		25
53	80.0333.31	Nozzle holder, 3/8M Bsp brass+Ni	1					3
54	25.0019.51	Nozzle, 02 d.10,5x15 mm Sst.	1					5
55	10.3052.00	O-ring, 1,78x6,75 mm	1	•	•	•		25
56	80.0348.31	Coupl., 3/8M Bsp-M22x1 M brass+Ni	1					3
57	80.0349.35	T-fitting, 3/8Bsp FFF brass+Ni	1					3
58	80.0402.31	Slide valve, 3/8M-1/4M Bsp brass	1					3
59	80.0403.21	Knob, PA black + Insert, brass	1					3
60	29.0402.51	Snap ring, 1,6x14,3 mm Sst.	1					5
61	10.3058.10	O-ring, 1,78x10,82 mm Vi 70	3				•	10
62	10.4058.00	Back-up ring, opn. 14x16x2 mm	3				•	10
63	80.0400.00	Flow regulator -RF1, 3/8M -1/4M Bsp	1					3
64	26.0252.51	Snap ring, 1,5x15,5 mm Sst.	1					10
65	26.0261.31	Plug, 14mm-1/4F Bsp brass	1					10
66	26.0260.22	Hand nut, M22x1,5 - 17,5mm black	1					10
67	10.4010.01	Back-up ring,10,2x13,9x1,2mm	1	•	•	•		50
68	25.4320.24	Nozzle kit M4 - M21E 2x5pcs.	1					1
69	25.4353.20	Exten.-M21E 20m 12V DC MF **	1					1
70	80.0380.00	Suction tube, for Ø940mm barrel **	1					1
70	80.0386.00	Suction tube, for Ø1070mm barrel **	1					1
71	10.3066.10	O-ring, 1,78x15,6 mm Vi 70	2		•			10
75	14.3911.00	Washer, 13,5x19x1,5 mm Cu	1					10
76	14.6552.00	Teflon silicon grease x30g.>All **	1					2

** On request

Kit	P/N	Description	
K1	25.4320.24	Nozzle kit M4 - M21E 2x5pcs.	1
K2	25.4356.24	Seals Kit -M25E (S/No.1-100) 13x1pcs.	1
K3	25.4357.24	Seals Kit - M25E (S/No.101-518) 12x1pcs.	1
K4	25.4360.24	Seals Kit - M25E (S/No.519>) 13x1pcs.	1

(1) 25.4350.00 (2) 25.4350.25 (3) 25.4350.60

25.4363.00 M25E test.mot.elettr+aspir.,fless.
 25.4363.24 M25E test.mot.elettr+aspir.,fless. AUS

25.4363.25 M25E test.mot.elettr+aspir.,fless.24Vca
 25.4363.60 M25E test.mot.elett+aspir.,fless.Usa+Austr

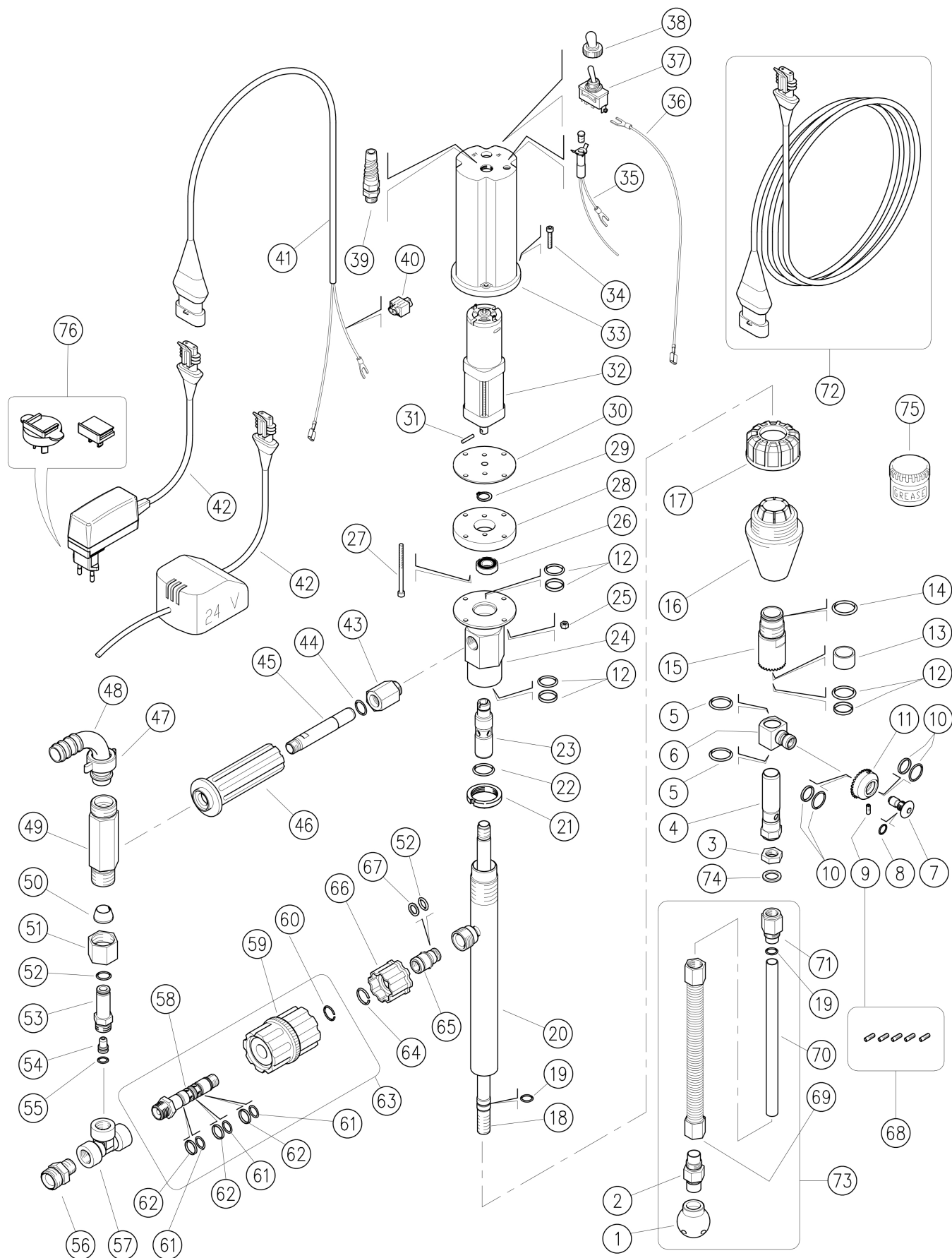

Pos.	Codice	Descrizione	Q.tà	K1	K2	K3	K4	Pos.	Codice	Descrizione	Q.tà	K1	K2	K3	K4
1	80.0330.81	Respingente forato POM bianco	1				5	37	12.5016.20	Interr.unipol. on/off +protezione	1				3
2	80.0367.51	Racc. M16x1 M inox	1				1	39	13.5997.00	Pressacavo 1/4 +protezione	1				5
3	80.0328.51	Ghiera G1/4F inox	1				5	40	12.5019.47	Rubacorrente	1				5
4	80.0327.51	Perno porta guarnizioni inox	1				5	41	12.5019.10	Cavo 2x1,5 mm 10m+connessione F	1				5
5	10.3010.10	An.OR 1x18 mm Vi 70	2	•			10	42	12.5071.00	Trasf. 230Vca/12Vcc EU (1)	1				1
6	80.0331.51	Statore inox	1				1	42	12.5071.24	Trasf. 240Vca/12Vcc AUS (2)	1				1
7	80.0325.51	Perno M10x1 inox	1				1	42	12.5071.25	Trasf. 24Vca/12Vcc EU (3)	1				1
8	10.3055.10	An.OR 1,78x7,66 mm Vi 70	1	•			10	42	12.5071.60	Trasf. 115Vca-60Hz/12Vcc USA (4)	1				1
9	15.3704.00	Tappo M4 plast.	2				4	43	80.0338.31	Racc. M16x1 M ott.+Ni	1				10
9	80.0350.51	Ugello 02 - 1,0mm - M4 inox verde ch.	2	•			10	44	10.3179.10	An.OR 2,62x13,94 mm Vi 70	1	•			10
9	80.0351.51	Ugello 025 - 1,1mm - M4 inox rosa	2	•			10	45	80.0337.56	Tube aspirazione G1/4M 113mm inox	1				3
9	80.0352.51	Ugello 03 - 1,2mm - M4 inox bianco	2	•			10	46	80.0344.85	Manopola 32x110mm PP nera	1				5
9	80.0353.51	Ugello 035 - 1,3mm - M4 inox marrone	2	•			10	47	80.0347.35	Girello G3/4 ott.+Ni	1				5
9	80.0354.51	Ugello 04 - 1,4mm - M4 inox giallo	2	•			10	48	80.0346.35	Gomito ptgm 20mm ott.+Ni	1				3
10	10.2030.00	Guarn. stelo 15x20x2,2 mm +OR	2	•			4	49	80.0336.31	Racc. venturi ott.+Ni	1				3
11	80.0326.51	Pignone portaug. z.41 M4 FF inox	1				3	50	80.0335.81	An.conico a. 14x20x11mm POM bianco	1				10
12	10.2030.18	Guarn. stelo 18x23x2 mm +OR Epdm	3	•			5	51	80.0334.31	Ghiera M24x1,5 ott.+Ni	1				5
13	80.0024.85	Boccola a. 18x22x14,8mm PTFE	1				5	52	10.3109.95	An.OR 2,4x9,3 mm Vi 70	2	•			25
14	10.3026.10	An.OR 1,5x20 mm Vi 70	1	•			10	53	80.0333.31	Racc. porta ugello G3/8M ott.+Ni	1				3
15	80.0372.23	Pignone z.34 inox+Bocc.ap. PTFE	1				3	54	25.0019.51	Ugello 02 d.10,5x15 mm inox	1				5
16	80.0365.84	Tappo conico corto TPes nero	1				3	55	10.3052.00	An.OR 1,78x6,75 mm	1	•			25
17	80.0316.84	Ghiera PP nera	1				10	56	80.0348.31	Racc. G3/8M-M22x1 M ott.+Ni	1				3
18	80.0364.56	Tube G1/4 MM 420mm inox	1				3	57	80.0349.35	Racc. a T G3/8 FFF ott.+Ni	1				3
19	10.3007.10	An.OR 1x12 mm Vi 70	2	•			10	58	80.0402.31	Racc. distrib. G3/8M-G1/4M ott.	1				3
20	80.0362.21	Tube 322mm + raccordo M22 inox	1				3	59	80.0403.21	Manopola PA nera + Inserto ott.	1				3
21	80.0012.51	Ghiera M28x1 inox	1				1	60	29.0402.51	An. elast. 1,6x14,3 mm inox	1				5
22	10.3205.10	An.OR 2,62x26,64 mm Vi 70	1	•			10	61	10.3058.10	An.OR 1,78x10,82 mm Vi 70	3	•			10
23	80.0321.51	Albero di trasmissione inox	1				1	62	10.4058.00	An.tenuta 14x16x2 mm	3	•			10
24	80.0341.21	Collettore inox	1				2	63	80.0400.00	Regolat. di portata RF1 G3/8M-G1/4M	1				3
25	11.4513.10	Dado es. M4 inox	4				10	64	26.0252.51	An. elast. 1,5x15,5 mm inox	1				10
26	11.4412.28	Cuscinetto 12x28x8 mm - 2RS1 inox	1				3	65	26.0261.31	Spinotto 14mm-G1/4F ott.	1				10
27	16.1860.00	Vite DIN912 M4x60 mm inox	2				10	66	26.0260.22	Girello M22x1,5 17,5mm nero	1				10
28	80.0318.41	Flangia motore	1				3	67	10.4010.01	An. anties. a. 10,2x13,9x1,2 mm	1	•			50
29	10.0999.05	An. elast. E 12 inox	1				10	68	25.4320.24	Kit Ugelli M4 - M21E 2x5pz.	1				1
30	80.0317.88	Guarniz. per motore, NBR	1				2	69	80.0371.21	Molla inox	1				1
31	15.1030.00	Spina elast. 3x16 mm inox	1				10	70	80.0370.86	Tube 10x12, 339mm PA bianco	1				1
32	13.0827.00	Motoriduttore 12V 10Rpm	1				1	71	80.0366.51	Racc. aspiraz. G1/4F-M16x1 M inox	1				1
33	80.0301.84	Carter motore PA nero	1				1	72	25.4353.20	Prol. -M21E 20m 12Vcc MF **	1				1
34	16.1856.00	Vite DIN912 M4x25 mm inox	4				10	73	25.4367.24	Kit tubo aspirante M25E, 6x1pz.	1				1
35	12.5019.31	Lampada spia	1				5	74	14.3911.00	Rosetta 13,5x19x1,5 mm Cu	1				10
36	12.5019.25	Cavo 1x0,75 L.250 mm	1				5	75	14.6552.00	Grass.silicone-teflon-30g.>tutti imp. **	1				2

** Su richiesta

Kit	Codice	Descrizione	Q.tà
K1	25.4320.24	Kit Ugelli M4 - M21E 2x5pz.	1
K2	25.4360.24	Kit ric.guarn. M25E (mat.519>) 13x1pz.	1

(1) 25.4363.00 (2) 25.4363.24 (3) 25.4363.25 (4) 25.4363.60

25.4363.00 M25E Barrel cl.,elect.driv+suct.,flex.
 25.4363.24 M25E Barrel cl.,el.driv+suct.,flex. AUS

25.4363.25 M25E Barrel cl.,elect.driv+suct.,flex.
 25.4363.60 M25E Barrel cl.,el.driv+suct.,flex.Usa+Aust

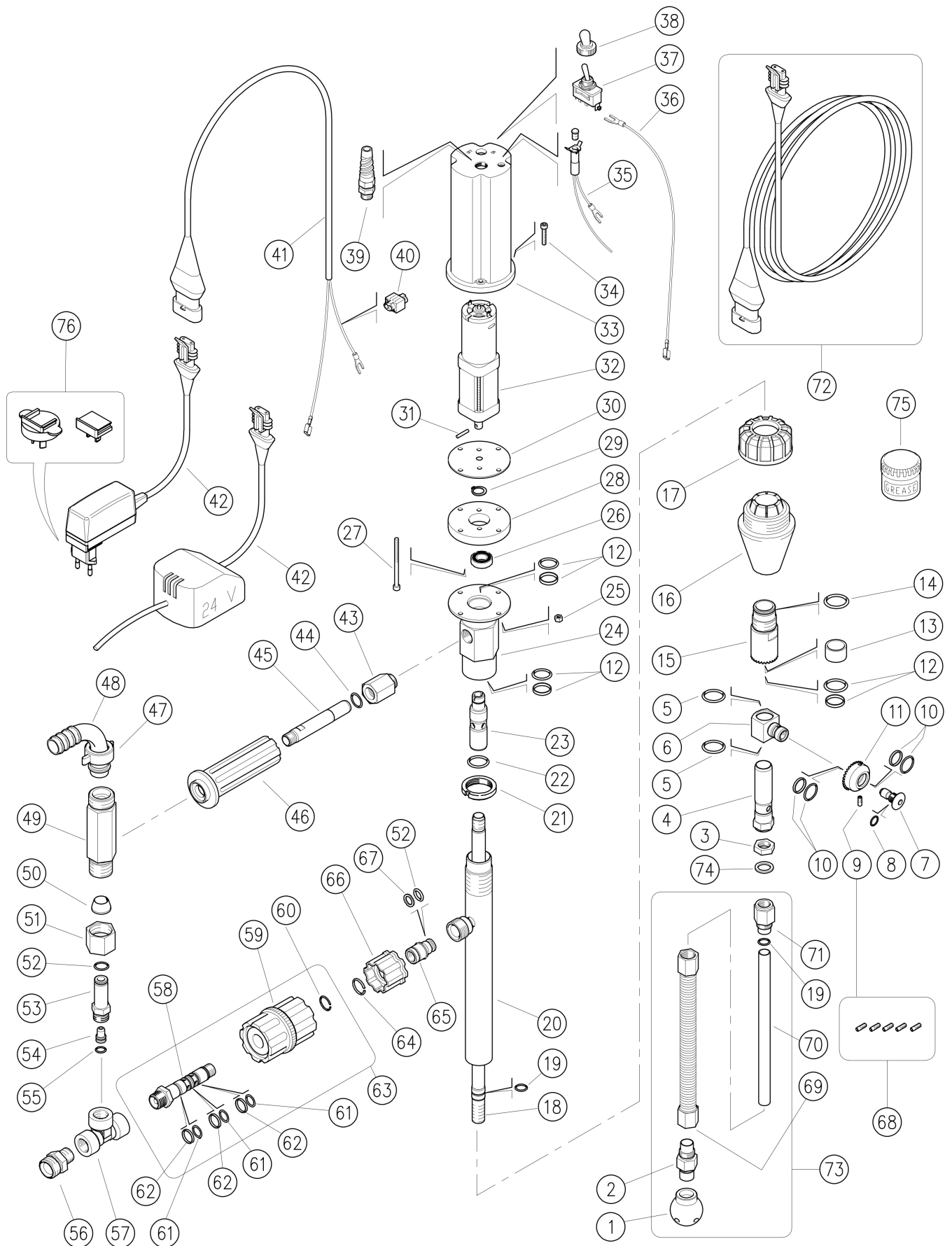

Pos.	P/N	Description	Q.ty	K1	K2	K3	K4	Pos.	P/N	Description	Q.ty	K1	K2	K3	K4
1	80.0330.81	Pierced buffer, POM white	1				5	37	12.5016.20	On/off unipol. switch+protec.	1				3
2	80.0367.51	Coupl., M16x1 M Sst.	1				1	39	13.5997.00	Cable gland 1/4 +protection	1				5
3	80.0328.51	Ring nut, 1/4F Bsp Sst.	1				5	40	12.5019.47	Wire tap-in	1				5
4	80.0327.51	Seal holding pin, Sst.	1				5	41	12.5019.10	Cable, 2x1,5 mm 10m+F connection	1				5
5	10.3010.10	O-ring, 1x18 mm Vi 70	2	•			10	42	12.5071.00	Transf. 230VAC/12VDC EU (1)	1				1
6	80.0331.51	Stator, Sst.	1				1	42	12.5071.24	Transf. 240VAC/12VDC AUS (2)	1				1
7	80.0325.51	Pin, M10x1 Sst.	1				1	42	12.5071.25	Transf. 24VAC/12VDC EU (3)	1				1
8	10.3055.10	O-ring, 1,78x7,66 mm Vi 70	1	•			10	42	12.5071.60	Transf. 115VAC-60Hz/12VDC USA (4)	1				1
9	15.3704.00	Plug, M4 plast.	2				4	43	80.0338.31	Coupl., M16x1 M brass+Ni	1				10
9	80.0350.51	Nozzle, 02 - 1,0mm - M4 Sst. light green	2	•			10	44	10.3179.10	O-ring, 2,62x13,94 mm Vi 70	1	•			10
9	80.0351.51	Nozzle, 025 - 1,1mm - M4 Sst. pink	2	•			10	45	80.0337.56	Intake tube, 1/4M Bsp 113mm Sst.	1				3
9	80.0352.51	Nozzle, 03 - 1,2mm - M4 Sst. white	2	•			10	46	80.0344.85	Knob, 32x110mm PP black	1				5
9	80.0353.51	Nozzle, 035 - 1,3mm - M4 Sst. brown	2	•			10	47	80.0347.35	Hand nut, G3/4 brass+Ni	1				5
9	80.0354.51	Nozzle, 04 - 1,4mm - M4 Sst. yellow	2	•			10	48	80.0346.35	Elbow+hose barb, 20mm brass+Ni	1				3
10	10.2030.00	Stem seal, 15x20x2,2 mm +O-ring	2	•			4	49	80.0336.31	Venturi fitting, brass+Ni	1				3
11	80.0326.51	Nzl hold. pinion, z.41 M4 FF Sst.	1				3	50	80.0335.81	Taper.ring.opn. 14x20x11mm POM white	1				10
12	10.2030.18	Stem seal, 18x23x2 mm +O-ring Epdm	3	•			5	51	80.0334.31	Ring nut, M24x1,5 brass+Ni	1				5
13	80.0024.85	Bushing, opn. 18x22x14,8mm PTFE	1				5	52	10.3109.95	O-ring, 2,4x9,3 mm Vi 70	2	•			25
14	10.3026.10	O-ring, 1,5x20 mm Vi 70	1	•			10	53	80.0333.31	Nozzle holder, 3/8M Bsp brass+Ni	1				3
15	80.0372.23	Pinion, z.34 Sst.+bushing,opn.PTFE	1				3	54	25.0019.51	Nozzle, 02 d.10,5x15 mm Sst.	1				5
16	80.0365.84	Tapered plug, short TPEs black	1				3	55	10.3052.00	O-ring, 1,78x6,75 mm	1	•			25
17	80.0316.84	Ring nut, PP black	1				10	56	80.0348.31	Coupl., 3/8M Bsp-M22x1 M brass+Ni	1				3
18	80.0364.56	Tube, 1/4Bsp MM 420mm Sst.	1				3	57	80.0349.35	T-fitting, 3/8Bsp FFF brass+Ni	1				3
19	10.3007.10	O-ring, 1x12 mm Vi 70	2	•			10	58	80.0402.31	Slide valve, 3/8M-1/4M Bsp brass	1				3
20	80.0362.21	Tube, 322mm + coupling, M22 Sst.	1				3	59	80.0403.21	Knob, PA black + Insert, brass	1				3
21	80.0012.51	Ring nut, M28x1 Sst.	1				1	60	29.0402.51	Snap ring, 1,6x14,3 mm Sst.	1				5
22	10.3205.10	O-ring, 2,62x26,64 mm Vi 70	1	•			10	61	10.3058.10	O-ring, 1,78x10,82 mm Vi 70	3	•			10
23	80.0321.51	Propeller shaft, Sst.	1				1	62	10.4058.00	Back-up ring, opn. 14x16x2 mm	3	•			10
24	80.0341.21	Manifold, Sst.	1				2	63	80.0400.00	Flow regulator -RF1, 3/8M -1/4M Bsp	1				3
25	11.4513.10	Hex. nut, M4, Sst.	4				10	64	26.0252.51	Snap ring, 1,5x15,5 mm Sst.	1				10
26	11.4412.28	Ball-bearing, 12x28x8 mm - 2RS1 Sst.	1				3	65	26.0261.31	Plug, 14mm-1/4F Bsp brass	1				10
27	16.1860.00	Screw, DIN912 M4x60 mm Sst.	2				10	66	26.0260.22	Hand nut, M22x1,5 - 17,5mm black	1				10
28	80.0318.41	Motor flange	1				3	67	10.4010.01	Back-up ring,10,2x13,9x1,2mm	1	•			50
29	10.0999.05	Snap ring, E 12 Sst.	1				10	68	25.4320.24	Nozzle kit M4 - M21E 2x5pcs.	1				1
30	80.0317.88	Motor seal, NBR	1				2	69	80.0371.21	Spring, Sst.	1				1
31	15.1030.00	Roll pin, 3x16 mm Sst.	1				10	70	80.0370.86	Hose, 10x12, 339mm PA white	1				1
32	13.0827.00	Gearmotor, 12V 10Rpm	1				1	71	80.0366.51	Suction coupl., 1/4F Bsp-M16x1 M Sst.	1				1
33	80.0301.84	Motor casing, PA black	1				1	72	25.4353.20	Exten.-M21E 20m 12V DC MF **	1				1
34	16.1856.00	Screw, DIN912 M4x25 mm Sst.	4				10	73	25.4367.24	Suction tube kit -M25E, 6x1pcs.	1				1
35	12.5019.31	Pilot lamp	1				5	74	14.3911.00	Washer, 13,5x19x1,5 mm Cu	1				10
36	12.5019.25	Cable, 1x0,75 L.250 mm	1				5	75	14.6552.00	Teflon silicon grease x30g.>All **	1				2

** On request

Kit	P/N	Description	Q.ty
K1	25.4320.24	Nozzle kit M4 - M21E 2x5pcs.	1
K2	25.4360.24	Seals Kit - M25E (S/No.519>) 13x1pcs.	1

(1) 25.4363.00 (2) 25.4363.24 (3) 25.4363.25 (4) 25.4363.60



P.A. S.p.A.

Via Milano, 13
42048 Rubiera, Reggio Emilia - Italy

Tel +39.0522.623611
Fax +39.0522.629600

info@pa-etl.it

www.pa-etl.it



COMPANY WITH QUALITY MANAGEMENT
SYSTEM CERTIFIED BY DNV
= ISO 9001 =