



NEW!

181-VL

High Temperature
Heat Recovery
Undercounter Glasswasher



MODEL CMA 181-VL

FEATURES:

- Soft Start feature lowers noise and reduces chance of glass breakage
- Reduces water vapor for under bar application
- Heat Recovery System promotes faster drying of glasses
- 304 Stainless Steel construction
- 20 racks or 600 glasses per hour (30 glasses per rack)
- .73 gallon of water per cycle or rack
- Safe-T-Temp booster heater for a 70°F rise
- 180°F fresh water final rinse
- Detergent and rinse aid chemical pumps
- 178 seconds cycle
- Removable Stainless Steel pump protection screen for easy cleaning
- Reduced energy costs-uses only cold water supply
- Raised door height makes it easier to remove racks
- 1.0 HP corrosion resistant pump
- Stainless Steel upper and lower wash and rinse arms
- Automatic fill function
- Energy Star Approved
- Standard 6" legs



Top mounted controls are easy to read and simple to operate.



Standard 6" legs for increasing the overall height to 37-3/8" is standard.



Large 11-1/4" height clearance accommodates larger glassware.

Options Available: CMA 181-VL

- Stainless Steel Pedestal
24"W X 25-3/8"D X 15-1/4"H
- 4 Inch legs Part # 1146.50 (4 needed)





181-VL

High Temperature
Heat Recovery
Undercounter Glasswasher

WARNINGS:

- Plumbing connections must be made by a qualified service company who will comply with all available Federal, State, and Local Health, Plumbing and Safety codes.
- CMA recommends utilizing a water softening system to maintain water hardness measurements of 3.5 gpg (grains per gallon) or less. This will assure maximum results and optimum operation of the dishmachine.

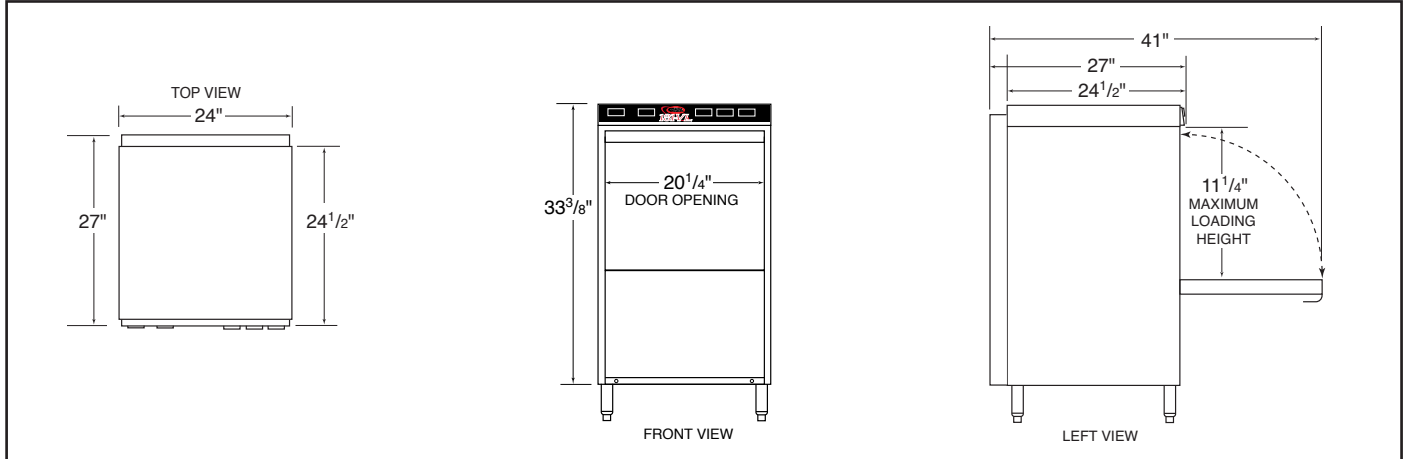

Specifications:

CMA 181-VL	USA	(Metric)	CMA 181-VL	USA	(Metric)
WATER CONSUMPTION			FRAME DIMENSIONS		
PER RACK	.73 GAL.	(2.76 L)	DEPTH	27"	(68.6 CM)
PER HOUR	12.4 GAL.	(46.93 L)	WIDTH	24"	(60.96 CM)
OPERATING CYCLE			HEIGHT	33-3/8"	(84.77 CM)
WASH TIME-SEC	96	96	MAX CLEARANCE FOR WARES	11-1/4"	(28.6 CM)
RINSE TIME-SEC	14	14	WASH PUMP MOTOR 1 HP 1 HP		
DWELL TIME-SEC	3	3	ELECTRICAL RATING		
VENT FAN-SEC	65	65	TOTAL AMPS	208 VOLTS 1 PH-60 Hz 33.0 AMPS	230 VOLTS 1 PH-60 Hz 35.0 AMPS
TOTAL CYCLE TIME-SEC	178	178	BOOSTER HEATER KW	5.3 KW	6.5 KW
OPERATING CAPACITY			THIS SYSTEM REQUIRES THREE POWER WIRES WHICH INCLUDES A CURRENT CARRYING NEUTRAL. AN ADDITIONAL FOURTH WIRE MUST BE PROVIDED FOR MACHINE GROUND. NO GFI BREAKER.		
RACKS PER HOUR	17.3	17.3			
WASH TANK CAPACITY	2.5 GAL.	(9.46 L)	APPROXIMATE SHIPPING WEIGHT 272# (123 KG)		
PUMP CAPACITY	38 GPM	(144 LPM)	SHIPPING DIMENSIONS PALLET & BOX 29" X 28" X 41"		
WATER REQUIREMENTS					
COLD WATER TEMP	41-65°F	(5-18°C)			
WATER INLET	1/2"	(1.27 CM)			
DRAIN CONNECTION	1"	(2.54 CM)			
RINSE PRESSURE SET	20 ± 5PSI	1.41 KG/CM²			
CYCLE TEMPERATURES					
WASH-°F	150° F-160° F	(65.5°C/71°C)			
RINSE-°F	180° F-195° F	(82°C/90°C)			

Summary Specifications: CMA 181-VL

The CMA 181-VL undercounter dishmachine with heat recovery technology reduces hot water vapor at end of cycle, provides hot water (180°F) sanitizing through the use of a built-in booster heater. 180°F final rinse safety system ensures proper temperatures in the final rinse by holding wash cycle in run mode until 180°F rinse temperature is detected. The unit comes standard with upper and lower stainless steel wash and final rinse arms, digital LED temperature gauges and easy to operate controls. The CMA 181-VL is constructed entirely of stainless steel. Uses standard 19-3/4"X19-3/4" glassracks with a 11-1/4" door clearance. This dishmachine only requires a cold water hookup.



CMA Dishmachines 12700 Knott Street, Garden Grove, CA 92841 • 800-854-6417 • 714-898-8781 • Fax: 714-895-2141 • www.cmadishmachines.com

CMA reserves the right to modify specifications or discontinue models without prior notification.

PN: 10126.17

© 8-2019 CMA, Inc.

an Ali Group Company



The Spirit of Excellence